

Measuring Cellular Repeaters Using the MT8220T BTS Master

Introduction

Signals transmitted from cellular base stations can sometimes be severely attenuated owing to obstructions such as large buildings, dense vegetation, civil engineering infrastructure, hills and mountains, etc. The area beyond these obstacles is often referred to as “radio shadow” and reduces the coverage area of a base station resulting in subscribers experiencing dropped calls, network access restrictions, low data throughput and an overall unsatisfactory user experience if they pass through or live in these areas. The effects are usually worsened at higher frequencies since the signal attenuation is greater.

It is an interesting observation, too, that the majority of cellular voice calls or data sessions are initiated or received in a relatively static location within buildings like homes, office blocks, shopping malls, arenas and stadiums. The very nature of the materials used in the construction of these buildings means that downlink signals from an external macro cellular base station are absorbed considerably as they propagate into the building causing, if not a complete radio shadow, much reduced coverage and poor communication quality. The same is the case for the uplink signals from the user equipment to the base station.

A common solution to both these scenarios is to use a repeater or bi-directional amplifier. However, for each, they are used in a slightly different way but effectively achieve the same outcome; extending the coverage of a macro base station. Figure 1 shows a typical schematic of an FDD cellular repeater where uplink and downlink signals are in separate frequency bands.

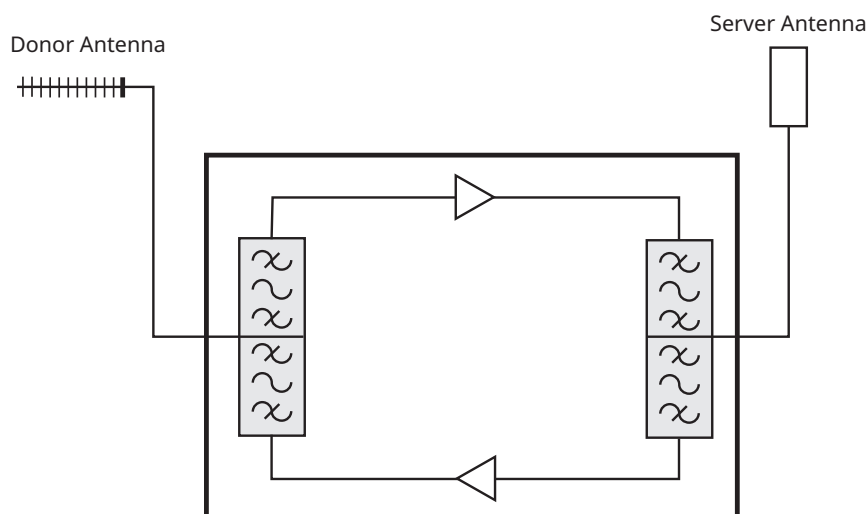

Figure 1: FDD Cellular Repeater

To overcome a radio shadow, the repeater would be strategically placed on a hill top or building for example (typically the obstacle that's causing the shadow). An antenna directed towards the macro base station (called the donor antenna) is used to receive the downlink signal which is then amplified and retransmitted via another antenna (the server antenna) aligned to illuminate the radio shadow (see Figure 2). For cellular applications, the repeater is bi-directional so the uplink signals are similarly amplified.

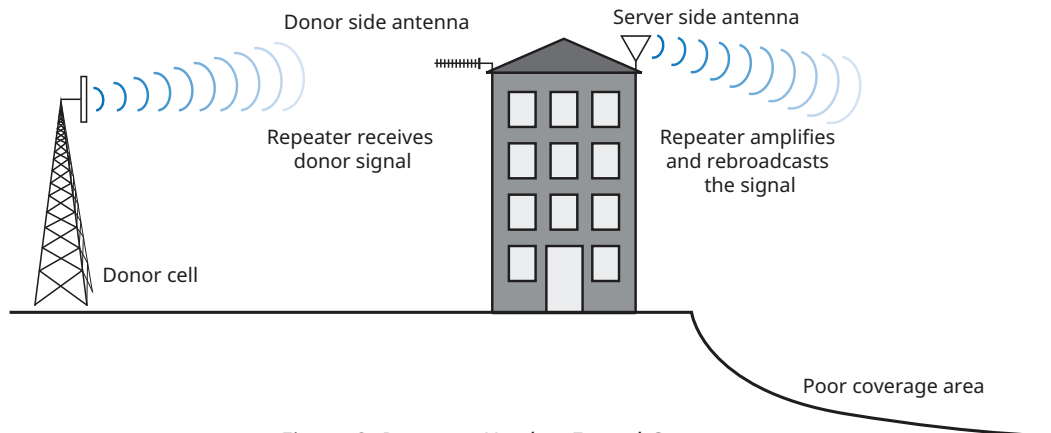

Figure 2: Repeater Used to Extend Coverage

For in-building, the use of a repeater is just one method to improve coverage. In this case, the donor antenna is usually placed high on the building to receive the downlink signal from the serving base station but then the amplified signal is propagated throughout the building by means of a distributed antenna system (DAS) as shown in Figure 3. Uplink signals are collected by the DAS and amplified in the repeater for transmission back to the base station.

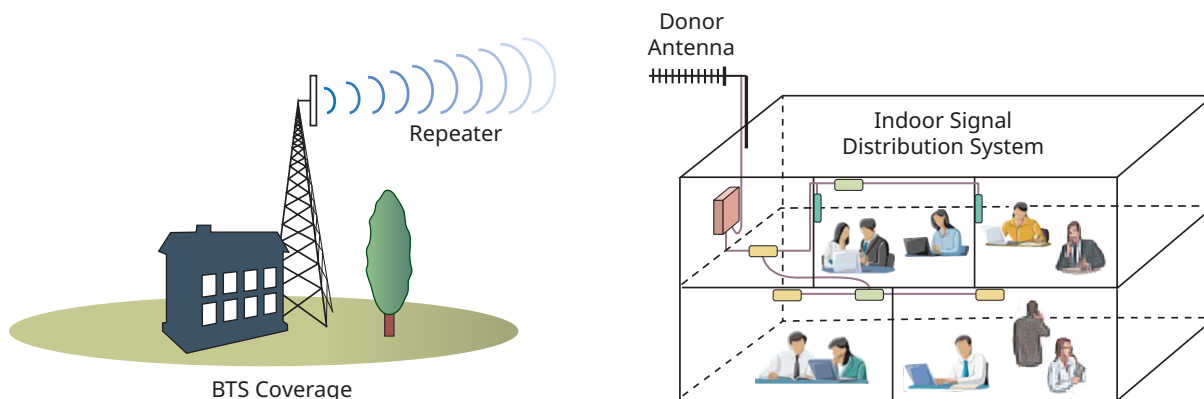

Figure 3: Repeater Driving a DAS

It should be noted that repeaters do not improve the potential capacity of a cell site since they provide no additional radio resources. However, a cell site may be under-utilized since its coverage area does not reach its intended subscriber base. Repeaters can have the net effect of extending coverage to support more subscribers, utilizing more of the available radio resources and improving the revenue generated from that cell site.

Practical Considerations

Repeaters typically are set to very high gain, anything up to 90 dB depending on the expected receive level by the donor antenna and the extent of the area needed to be serviced.

Since the received and retransmitted signals are at the same frequency, there should be enough isolation between the server and donor antennas such that the retransmitted signal detected by the donor antenna is significantly lower than the signal received from the serving macro cell base station transmitter.

Practically, the isolation should be a minimum of 10 dB greater than the gain of the repeater, and preferably 15 dB or more (Figure 4). If this condition is not met, there is a real possibility that the repeater will oscillate causing bad signal reception conditions.

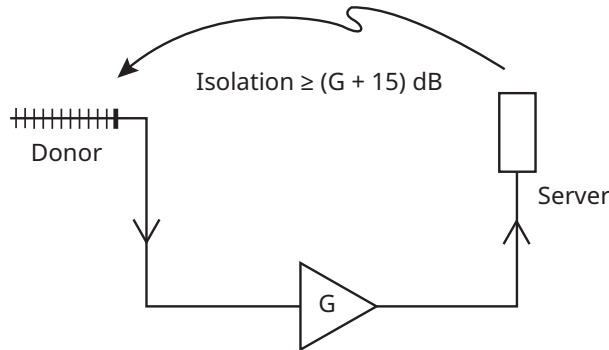

Figure 4: Repeater Gain and Antenna Isolation

Most repeaters have adjustable gain. Determining the gain required is dependent on the signal level received from the donor transmitter. This will vary depending on cellular technology and data traffic conditions. For example, the total signal power transmitted from an LTE base station with low subscriber traffic will be lower than the power transmitted when the base station is fully utilized. The required gain should be calculated with consideration to the maximum possible received power at the input otherwise the repeater could go into compression under high utilization conditions.

Along with subscriber traffic, cellular technologies transmit various control channel signals which are used for such things as identification, channel estimation and equalization, synchronization, etc. They are transmitted at a constant power and use a fixed proportion of the available radio resource. Therefore, by measuring control channel signal power, the maximum possible transmit power if all available radio resource was used can be simply calculated.

Methods for estimating maximum transmit power are beyond the scope of this application note. However, the reader may be interested in Anritsu's application note titled, "Measuring LTE eNodeB Output Power Without Interrupting Service" which describes how to calculate maximum power derived from the measurement of reference signal power.

Repeater Gain and Antenna Isolation

So, there are two fundamental measurements to be performed when installing or maintaining repeaters: gain and isolation between the server antenna and donor antenna in both downlink and uplink directions. The rest of this note describes the method for each of these measurements using the MT8220T BTS Master.

As described earlier, repeater gains can be very high and the corresponding antenna isolation higher. The MT8220T is uniquely positioned as a handheld field tester in that it has in excess of 100 dB 2-port dynamic range (typically 110 dB) in its cable and antenna analyzer function to measure high isolation and gain. (As a side note, along with many other Anritsu handheld testers, it is possible to install signal analysis options in the MT8220T for all cellular technologies which, among other measurements, allow the measurement of control channel power from which maximum power can be estimated in order that correct gain settings can be set on the repeater.)

Things to Know About the MT8220T 2-port Cable and Antenna Analyzer Mode

For both gain and isolation tests the “2-port gain” measurement mode is used. This mode has two output power settings: nominally -7 dBm (high power) and -40 dBm (low power). The high power setting is used for isolation tests and the low power setting is used for gain measurements.

Also note that, in either high or low power setting, the receiver at port 2 (RF In) of the MT8220T will clip and compress at about -5 dBm. We need to take this into consideration before making any measurements.

Things to Know About the Repeater to be Tested

The maximum input power needs to be known. Most repeaters should be driven below -40 dBm at the input to prevent damage or distortion. This has two implications. First, if the estimated maximum receive power at the donor antenna is greater than the maximum allowable input power to the repeater, the input should be padded down appropriately during installation. Second, when setting and measuring the gain, it's possible that the low power output of the MT8220T of -40 dBm will be too high. Again, an attenuator of appropriate value should be used (and compensated for) in the measurement.

The other parameter of importance is the maximum rated output power from the repeater. This should not be exceeded when in use or during gain setting and measurements. It is also very likely that the power output during the gain measurement will exceed the power at which port 2 of the MT8220T will clip. A suitable high-power-rated attenuator should be connected to the repeater output, and compensated for, to bring the power to port 2 to about -10 dBm (allowing for a 5 dB margin).

Gain Measurement Setup

Figure 5 shows the typical setup to perform a repeater gain measurement. G is the required or set gain.

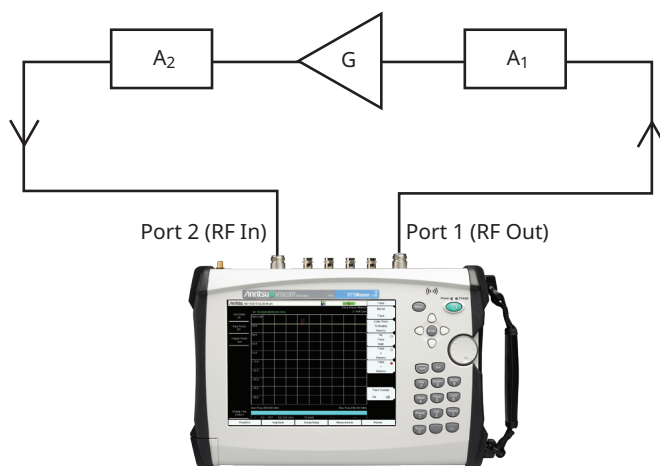

Figure 5: Gain Measurement Connection Setup

Input attenuator A_1 should be selected so that the resultant input power to the repeater is either:

- approximately the same as the estimated maximum input power when installed, or
- at a level where the required gain setting will not drive the repeater into compression.

Output attenuator A_2 should be chosen so that the input to port 2 is about -10 dBm and of sufficient power handling rating.

Example

A repeater needs to be set to 90 dB gain based on the estimated input power and the coverage required. The maximum output power is +25 dBm. Therefore, the maximum input power to allow 90 dB to be set is:

$$+25 - 90 = -65 \text{ dBm.}$$

It is always best to allow for at least 5 dB of margin so an input level of -70 dBm would be appropriate. Therefore, input attenuator A_1 should be:

$$(-40) - (-70) = 30 \text{ dB.}$$

Output power from the repeater would be:

$$-40 - A_1 + G = -40 - 30 + 90 = +20 \text{ dBm.}$$

Therefore, attenuator A_2 should be at least:

$$+20 - (-10) = 30 \text{ dB.}$$

and with a power handling capability of at least +20 dBm.

Both A_1 and A_2 values need to be taken into account and subtracted from the overall measurement in order that the true gain of the repeater can be measured. Of course, the attenuation values could be read from the labels and the total attenuation subtracted from the measurement trace results. However, this would not allow for any tolerances or frequency response associated with the attenuator specifications. The MT8220T has a convenient trace math feature which allows the repeater gain to be directly read.

Gain Measurement Method

To explain the gain measurement method, we'll look at a practical example.

- Downlink gain (G) set to 75 dB to 80 dB
- Frequency range 869 MHz to 894 MHz
- Maximum repeater input power -40 dBm
- Maximum repeater output power +30 dBm
- Estimated maximum receive power at donor antenna -70 dBm

Clearly, in this example, the MT8220T low power test signal of -40 dBm needs to be attenuated otherwise the repeater will go into compression. 30 dB attenuation ($A_1 = 30$ dB) is suitable and mirrors likely real life conditions after installation ($-40 - 30 = -70$ dBm input power).

Under these conditions, repeater output power will be:

$$-40 - A_1 + G = -40 - 30 + 80 = +10 \text{ dBm.}$$

This is well within the operating range of the repeater but will overdrive port 2 of the MT8220T. Therefore, attenuator A_2 should be:

$$+10 - (-10) = 20 \text{ dB minimum and rated to at least +10 dBm.}$$

In actuality, A_2 is set to 30 dB which allows some adjustment headroom during gain setting. Figure 6 shows the measurement connection diagram.

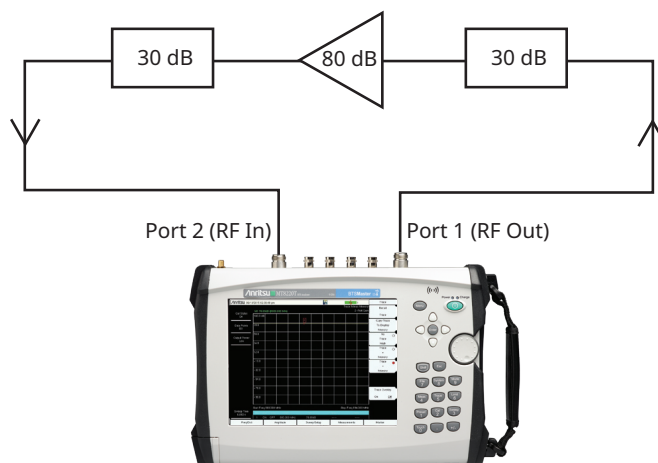

Figure 6: Repeater Gain Measurement Example

Procedure for this example: use appropriate settings for your setup

- Select 2-Port Gain measurement in Cable and Antenna Analyzer mode in the MT8220T
- Set frequency range (869 MHz to 894 MHz) and desired data point resolution
- Set output power to High
- Connect suitable test port leads and adapters to port 1 (RF Out) and port 2 (RF In) to make it convenient for connection to the attenuators and antennas
- Perform a 2-port calibration at the end of the test port leads and save the setup in internal memory. Label the setup file in a way which will remind you the calibration was performed at high output power
- Change the output power to Low
- Perform another 2-port calibration and label and save the setup file as before

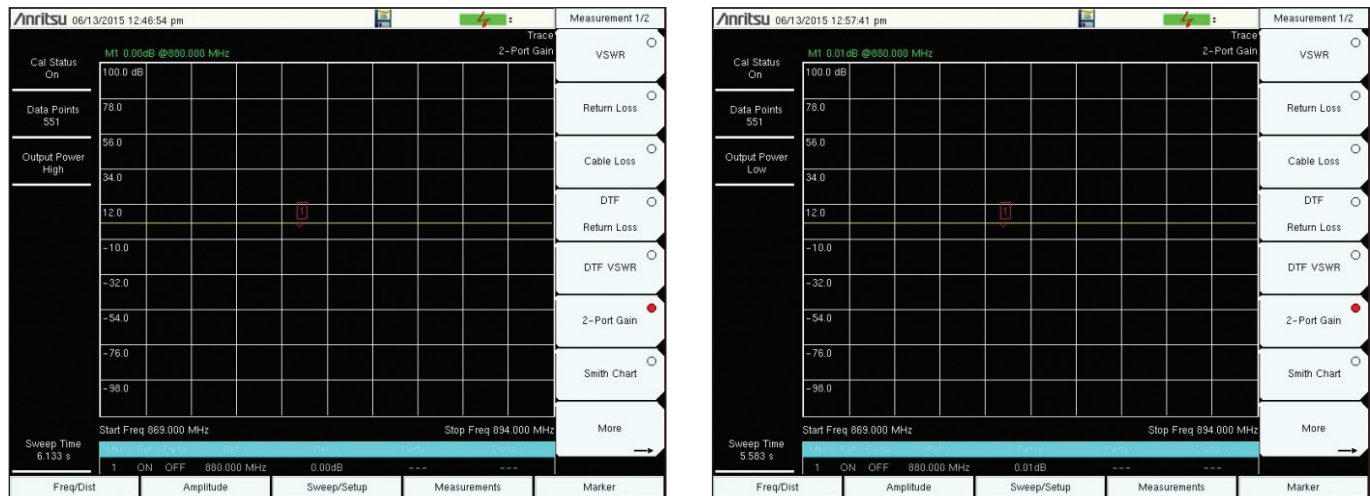

Figure 7: High Power and Low Power Calibration Traces

Both high power and low power calibrations will be needed throughout the gain and isolation measurement procedure. Performing both calibrations upfront and saving them to memory means no further calibration needs to be performed. Just recall the appropriate setup for the measurement and the MT8220T will be calibrated.

- Recall the high power calibration setup
- Connect in attenuators A_1 and A_2 as shown in Figure 8

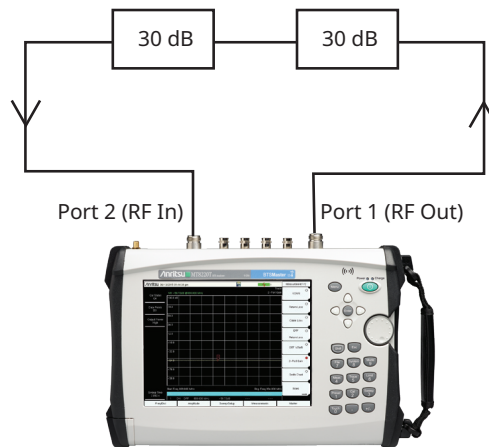

Figure 8: Measurement of Attenuators

- Measure combined A_1 and A_2 attenuation (Figure 9) and save the trace to internal memory. Label the saved file appropriately

It is better to measure the attenuators using high power output to make better use of the available dynamic range. Measuring them using low power output will reduce the signal to noise and increase the uncertainty of the measurement especially using high attenuation values. The purpose of this part of the procedure is to derive an accurate attenuation measurement which we'll eventually subtract from the overall measurement.

- **Recall the low power calibration setup!** This is most important before connecting in the repeater

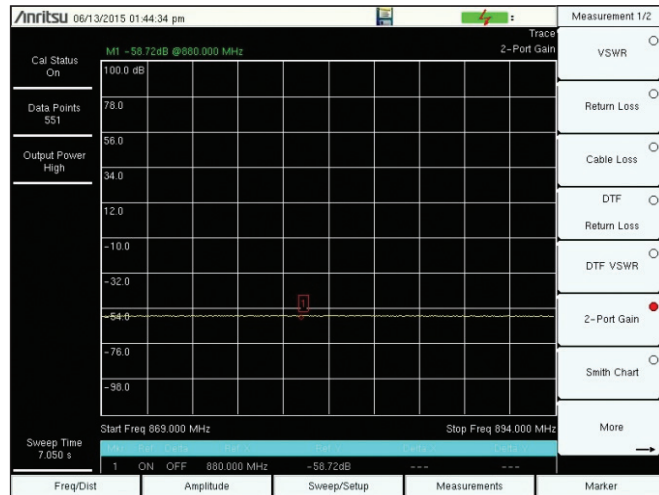

Figure 9: Measurement of Attenuators

- Connect in the repeater as shown in Figure 10

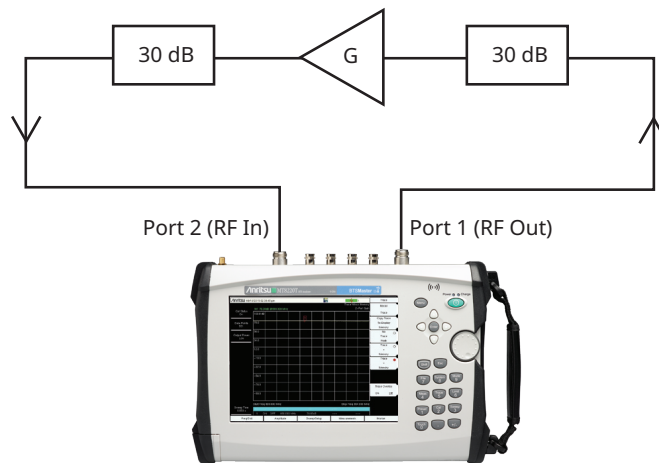

Figure 10: Connection Diagram for Repeater Gain Measurement

- In the Trace menu, recall the saved trace for the attenuator measurement and press “Copy Trace To Display Memory” softkey
- Press “Trace – Memory” softkey. (If you wish, you can turn on the Trace Overlay to view the attenuator measurement also)
- The Trace – Memory display is the gain of the repeater having removed the effects of the attenuators (see Figure 11)
- Adjust the gain of the repeater until the desired value is set



Figure 11: Repeater Gain Measurement Using Trace Math

Antenna Isolation Measurement Method

The isolation between the server antenna and donor antenna must be at least 10 dB greater than the repeater gain, preferably 15 dB or more, to prevent the potential resultant positive feedback putting the repeater into oscillation (refer to Figure 4). As described, repeater gains can be very high but the typical 2-port dynamic range of 110 dB or more of the MT8220T allows the measurement of isolation too.

Procedure for this example: use appropriate settings for your setup. It assumes the reader has performed the gain measurement procedure above. If not, follow the first five steps of the gain procedure to perform a high power calibration over the appropriate frequency range.

- Recall the high power calibration setup
- Connect the MT8220T as shown in Figure 12. Note: port 1 (RF Out) is connected to the server antenna; port 2 (RF In) is connected to the donor antenna

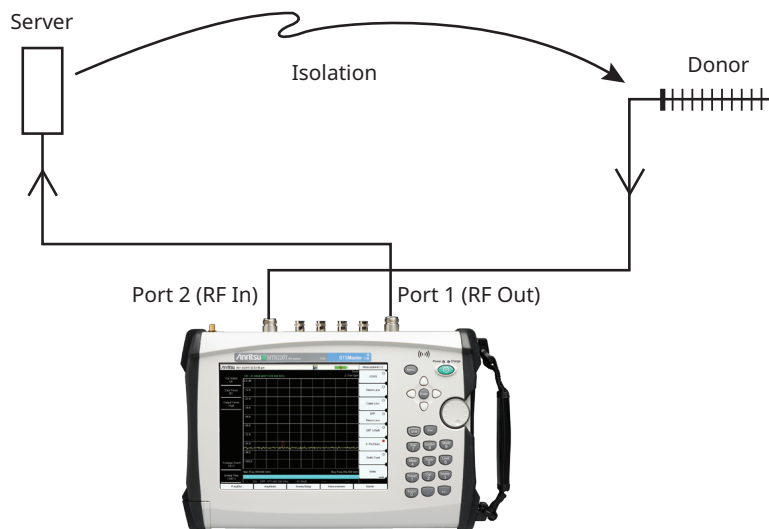

Figure 12: Antenna Isolation Connection Diagram

- Set trace averaging appropriately to obtain a smooth trace. In the example here, it is set to 10

Since isolation levels will be high, the signal to noise ratio for the measurement may be quite low. Averaging smooths the noise and makes the trace more stable and produces a more reliable measurement.

Figure 13 shows the isolation to be about 91 dB. The previous gain measurement was about 76 dB which means the isolation is about 15 dB greater than the gain. This is ideal. If the isolation is not good enough for the required gain setting, it can be improved by repositioning antennas, increasing antenna separation, adjusting polarization, using reflectors or shielding, etc.

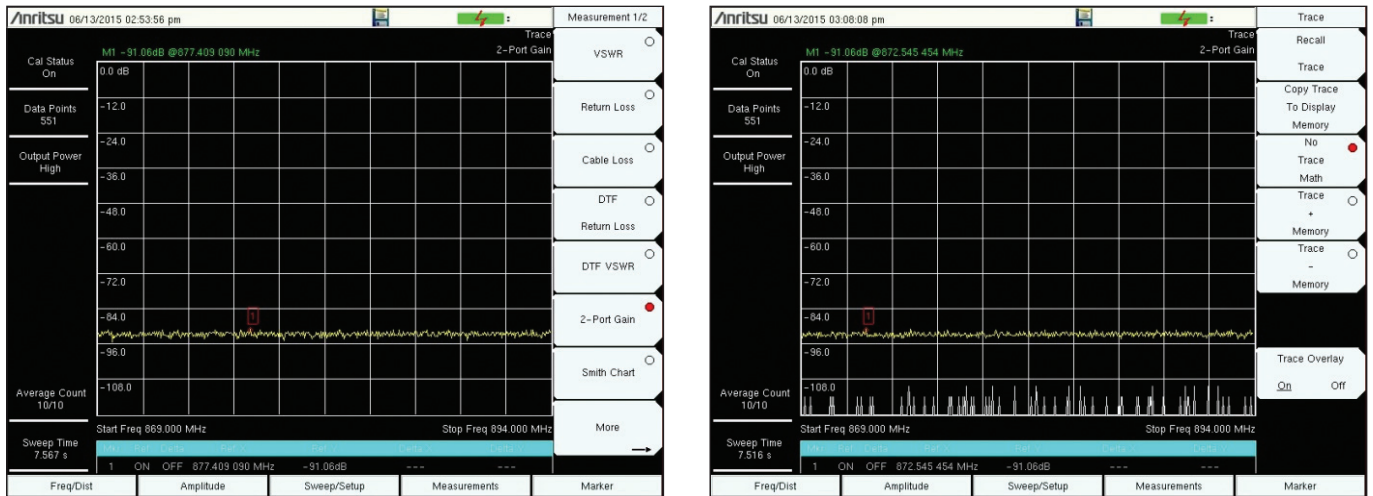

Figure 13: Antenna Isolation Measurement

The two traces in Figure 13 are showing the same isolation measurement. However, the trace on the right is comparing the measurement with a measurement of the MT8220T dynamic range (white trace) indicating that isolation measurements up to 110 dB are perfectly possible.

Conclusion

Repeaters are used extensively for all cellular technologies to increase the coverage area of a serving macro base station, both externally and within buildings. It is important to set the required gain accurately to achieve the coverage desired and to ensure the isolation between server and donor antennas is high enough to prevent oscillation issues. The typical 110 dB 2-port dynamic range of the MT8220T BTS Master allows the measurement of both parameters with ease during installation and routine maintenance.



• **United States**

Anritsu Company

1155 East Collins Boulevard, Suite 100,
Richardson, TX, 75081 U.S.A.
Toll Free: 1-800-267-4878
Phone: +1-972-644-1777
Fax: +1-972-671-1877

• **Canada**

Anritsu Electronics Ltd.

700 Silver Seven Road, Suite 120,
Kanata, Ontario K2V 1C3, Canada
Phone: +1-613-591-2003
Fax: +1-613-591-1006

• **Brazil**

Anritsu Eletrônica Ltda.

Praça Amadeu Amaral, 27 - 1 Andar
01327-010 - Bela Vista - São Paulo - SP - Brazil
Phone: +55-11-3283-2511
Fax: +55-11-3288-6940

• **Mexico**

Anritsu Company, S.A. de C.V.

Av. Ejército Nacional No. 579 Piso 9, Col. Granada
11520 México, D.F., México
Phone: +52-55-1101-2370
Fax: +52-55-5254-3147

• **United Kingdom**

Anritsu EMEA Ltd.

200 Capability Green, Luton, Bedfordshire LU1 3LU, U.K.
Phone: +44-1582-433280
Fax: +44-1582-731303

• **France**

Anritsu S.A.

12 avenue du Québec, Batiment Iris 1-Silic 612,
91140 Villebon-sur-Yvette, France
Phone: +33-1-60-92-15-50
Fax: +33-1-64-46-10-65

• **Germany**

Anritsu GmbH

Nemetschek Haus, Konrad-Zuse-Platz 1
81829 München, Germany
Phone: +49-89-442308-0
Fax: +49-89-442308-55

• **Italy**

Anritsu S.r.l.

Via Elio Vittorini 129, 00144 Roma Italy
Phone: +39-06-509-9711
Fax: +39-06-502-2425

• **Sweden**

Anritsu AB

Kistagången 20B, 164 40 KISTA, Sweden
Phone: +46-8-534-707-00
Fax: +46-8-534-707-30

• **Finland**

Anritsu AB

Teknobulevardi 3-5, FI-01530 VANTAA, Finland
Phone: +358-20-741-8100
Fax: +358-20-741-8111

• **Denmark**

Anritsu A/S

Kay Fiskers Plads 9, 2300 Copenhagen S, Denmark
Phone: +45-7211-2200
Fax: +45-7211-2210

• **Russia**

Anritsu EMEA Ltd.

Representation Office in Russia
Tverskaya str. 16/2, bld. 1, 7th floor.
Moscow, 125009, Russia
Phone: +7-495-363-1694
Fax: +7-495-935-8962

• **Spain**

Anritsu EMEA Ltd.

Representation Office in Spain

Edificio Cuzco IV, Po. de la Castellana, 141, Pta. 8
28046, Madrid, Spain
Phone: +34-915-726-761
Fax: +34-915-726-621

• **United Arab Emirates**

Anritsu EMEA Ltd.

Dubai Liaison Office

P O Box 500413 - Dubai Internet City
Al Thuraya Building, Tower 1, Suite 701, 7th floor
Dubai, United Arab Emirates
Phone: +971-4-3670352
Fax: +971-4-3688460

• **India**

Anritsu India Pvt Ltd.

2nd & 3rd Floor, #837/1, Binnamangla 1st Stage,
Indiranagar, 100ft Road, Bangalore - 560038, India
Phone: +91-80-4058-1300
Fax: +91-80-4058-1301

• **Singapore**

Anritsu Pte. Ltd.

11 Chang Charn Road, #04-01, Shriro House
Singapore 159640
Phone: +65-6282-2400
Fax: +65-6282-2533

• **P. R. China (Shanghai)**

Anritsu (China) Co., Ltd.

27th Floor, Tower A,
New Caohejing International Business Center
No. 391 Gui Ping Road Shanghai, Xu Hui Di District,
Shanghai 200233, P.R. China
Phone: +86-21-6237-0898
Fax: +86-21-6237-0899

• **P. R. China (Hong Kong)**

Anritsu Company Ltd.

Unit 1006-7, 10/F., Greenfield Tower, Concordia Plaza,
No. 1 Science Museum Road, Tsim Sha Tsui East,
Kowloon, Hong Kong, P. R. China
Phone: +852-2301-4980
Fax: +852-2301-3545

• **Japan**

Anritsu Corporation

8-5, Tamura-cho, Atsugi-shi,
Kanagawa, 243-0016 Japan
Phone: +81-46-296-1221
Fax: +81-46-296-1238

• **Korea**

Anritsu Corporation, Ltd.

5FL, 235 Pangyoyeok-ro, Bundang-gu, Seongnam-si,
Gyeonggi-do, 463-400 Korea
Phone: +82-31-696-7750
Fax: +82-31-696-7751

• **Australia**

Anritsu Pty Ltd.

Unit 21/270 Ferntree Gully Road,
Notting Hill, Victoria 3168, Australia
Phone: +61-3-9558-8177
Fax: +61-3-9558-8255

• **Taiwan**

Anritsu Company Inc.

7F, No. 316, Sec. 1, Neihu Rd., Taipei 114, Taiwan
Phone: +886-2-8751-1816
Fax: +886-2-8751-1817

